

A1 Microwave

Web: <http://www.A1Microwave.com>

Email: A1sales@A1Microwave.com



A1 Microwave is a leading designer and manufacturer of filters, diplexers, power combiners, couplers and adaptors for satcoms, telecoms, radar, medical and scientific applications.

A1 Microwave also provides standard and custom waveguide components and assemblies including : straights, bends, twists and flexibles.

A1 Microwave is ITAR free and provides a **Fast delivery and No NRE** (on standard designs) by using sophisticated in-house design and simulation software, all new **designs are "right first time"** allowing the design to move from the design computer to the machine shop without the need for prototyping. **Stock filters available for immediate despatch.**

A1 Microwave has full in house CNC machining, turning, brazing, hard and soft soldering and bending facilities.



Outline drawing

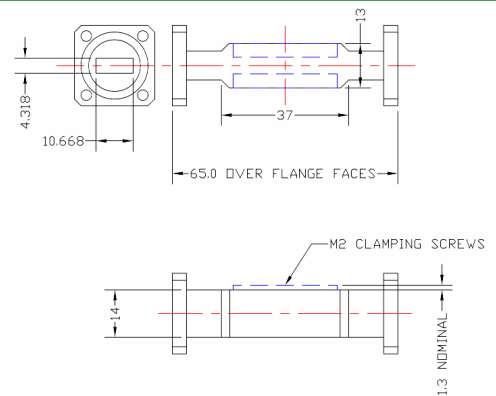

Ordering information :- Model number **PB1587WN-PB/PB-B** DBS-band Satcom TX Harmonic Reject Filter

Designed for DBS-band satcoms transmitter applications for suppressing unwanted transmitter harmonics.

Passband	17.7 to 21.3 GHz
Passband insertion loss	0.1 dB max
Passband group delay variation	1nS per 10 MHz max
Passband return loss	23 dB min, 25 dB typical
Rejection: 27.5 to 31 GHz	50 dB min, 70 dB typical
Overall length	65 mm nominal
Weight	90 grams max
Operating temperature range	-33 / +60 degrees C
Flanges	PBR 220 (see web site for alternative flanges and paint codes)

